

**ATTACHMENT 2
SEAT INTERFACES**

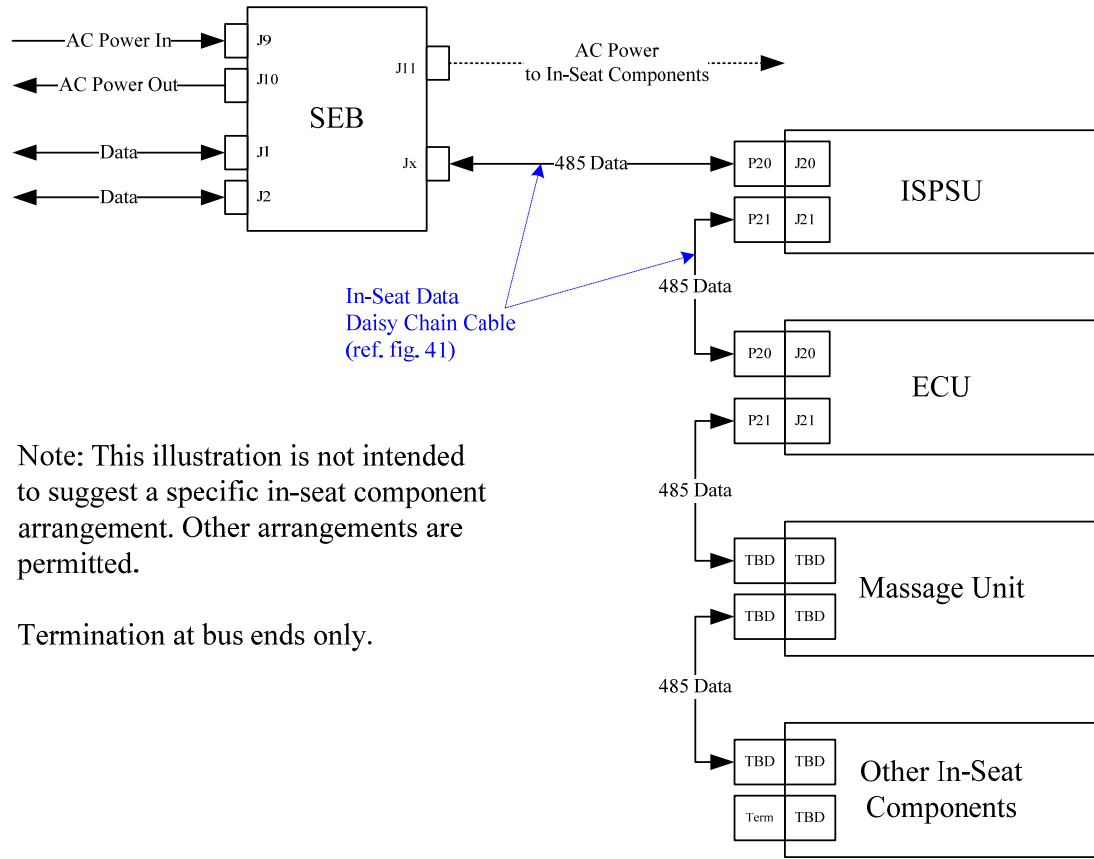

Note: This illustration is not intended to suggest a specific in-seat component arrangement. Other arrangements are permitted.

Termination at bus ends only.

Reference Designation	Connector	Part Number
J20	Receptacle Spring Latch	1SD9P0 Size 1
J21	Receptacle Spring Latch	1SD9S0 Size 1
P20	Plug Spring Latch Plate	1SD9S0 Size 1
P21	Plug Spring Latch Plate	1SD9P0 Size 1

Table 1. Connector Definition

Note: An optional slide latch connector is called out as a non-preferred option in Appendix D of ARINC Specification 628, Part 4A.

J20 Pin Outs	
Pin	Signal Description
1	ADDR0
2	ADDR1
3	ADDR2
4	ADDR3
5	RS485 HI
6	GND
7	GND
8	SHIELD
9	RS485 LO

J21 Pin Outs	
Pin	Signal Description
1	SHIELD
2	RS485 HI
3	TERM HI
4	SPARE
5	SPARE
6	RS485 LO
7	TERM LO
8	SPARE
9	SPARE

Table 2. Pin Out Definition

Figure 39 – SPSS Architecture

**ATTACHMENT 2
SEAT INTERFACES**

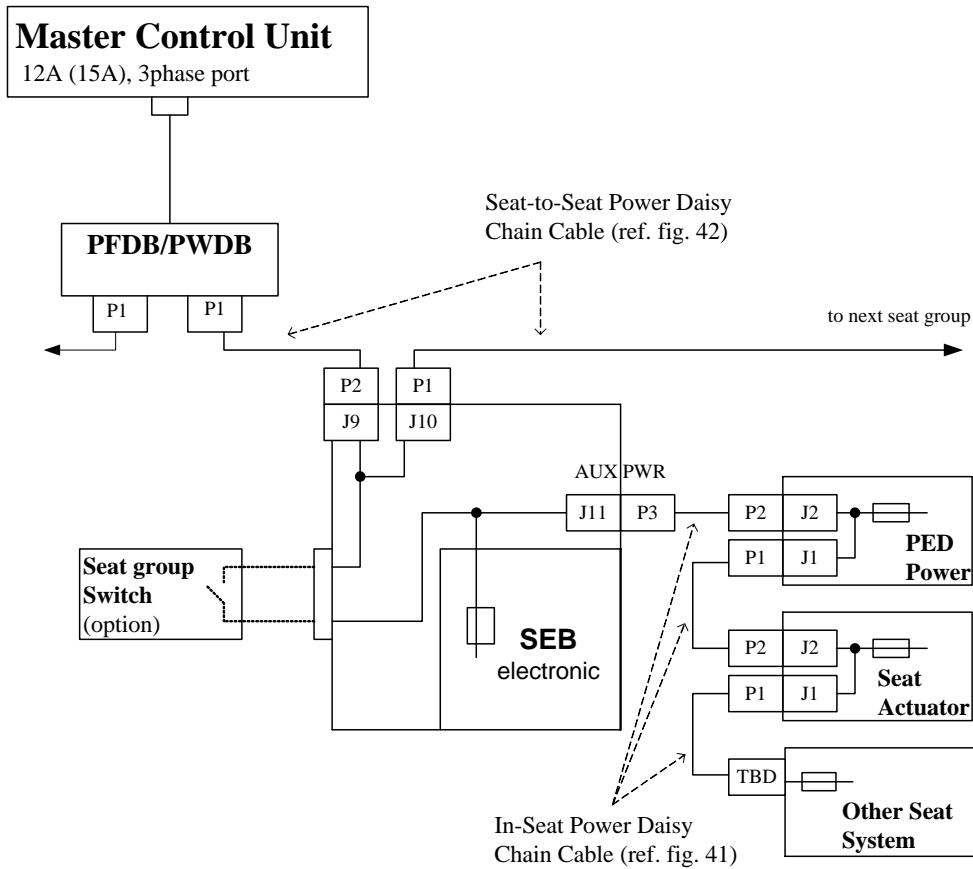

Note: The above shown sequence of connected in-seat systems is an example. Others are permitted.

Desig.	Connector	Part Number
J1 and J10	Receptacle	MS24264R14B7SN
J2 and J9	Receptacle	MS24264R14B7PN
J11	Receptacle	MS24264R14B7SN

Desig.	Connector	Part Number
P1	Plug	MS24266R14B7PN
P2	Plug	MS24266R14B7SN
P3	Plug	MS24266R14B7PN

Figure 40 – SPSS Architecture – Power Distribution

**ATTACHMENT 2
SEAT INTERFACES**

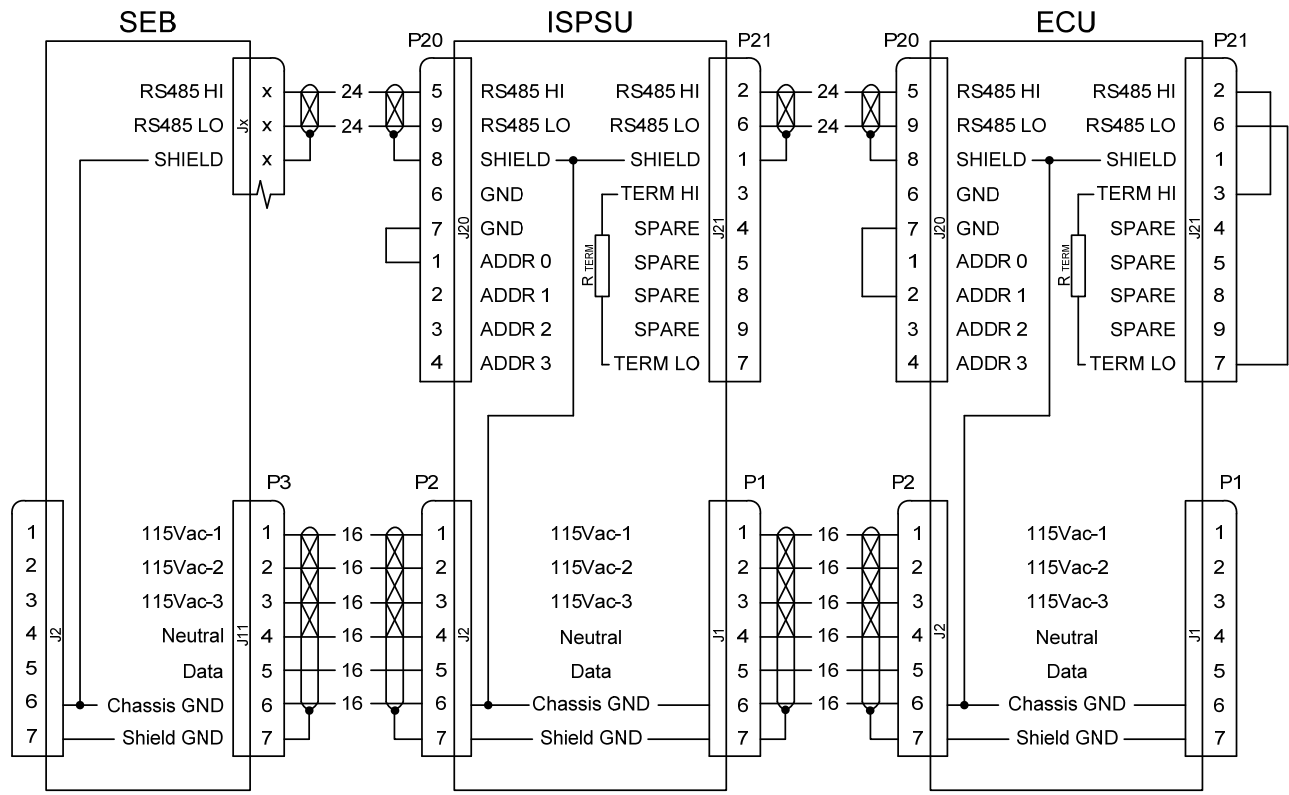

Notes:

1. The shield of the RS485 shall be internally connected to Chassis GND and shall be used as signal reference for the RS485 bus.
2. The shield of the power cable and the connection to pin 7 should be equivalent to diameter AWG 16.

Figure 41 – In-Seat Daisy Chain Cables